

MOPITT airborne validation instrument: MOPITT-A

George V. Bailak^{*a}, Gary R. Davis^b, James R. Drummond^a, Loic Jounot^a, Gurpreet Mand^a,
Andre Philips^b, Boyd T. Tolton^a

^aUniversity of Toronto, Department of Physics, Toronto, ON, Canada, M5S 1A7

^bInstitute for Space and Atmospheric Studies, University of Saskatchewan, Saskatoon, SK, Canada,
S7N 5E2

ABSTRACT

The Measurements of Pollution in the Troposphere – Aircraft (MOPITT-A) instrument is being constructed at the University of Toronto, as a primary data validation tool for the Terra based MOPITT instrument. MOPITT-A is designed to operate aboard a NASA ER-2 research aircraft and as such must be rugged and field serviceable while maintaining the same characteristics as the satellite instrument. The resulting instrument is a hybrid of flight spare components with commercial devices. Calibration data generated by both instruments, at the UofT Instrument Calibration Facility (ICF) will play a key role in data validation.

Keywords: MOPITT-A, MOPITT, data validation, ER-2, Terra, EOS-AM1, carbon monoxide, methane

1. INTRODUCTION

In 1995 the Engineering Qualification Model (EQM) of the MOPITT instrument was delivered to the University of Toronto for engineering and science tests. The EQM was used as a test bed in order to ensure that the final flight model would be capable of delivering sufficiently high quality data. As delivered, the EQM consisted of “half a MOPITT”. That is, the optics for channels 5 through 8 were built along with signal processing, command and telemetry circuits for these channels. The optical and signal processing components were manufactured to be as representative of the final instrument as possible. The remaining systems consisted of breadboard quality electronics, which allowed the test and design engineers to make changes as necessary to these scientifically non-critical items.

The instrument was tested at the UofT ICF using the same sources and procedures that were to be used in the Flight Model (FM) tests. The resulting data was used to make adjustments to both the EQM and FM designs. Upon shipment of the FM instrument to UofT in early 1997, the data obtained from EQM tests were used as a baseline and for comparison to FM results. The use of common techniques and test equipment proved to be valuable in the troubleshooting and fine-tuning of the flight instrument.

As part of the EOS program, NASA has made flight time available to instrument teams aboard their ER-2 aircraft. With its high altitude and long flight time the ER-2 provides an excellent platform for under-flight validation of MOPITT data. Since the validation plan¹ for MOPITT has always included aircraft under-flights of the Terra platform, it was decided that the EQM should become the basis of an aircraft version of MOPITT. Thus, any data retrieved from the aircraft instrument would have a long calibration heritage as well as a commonality to the FM instrument. Necessary to the proper operation of MOPITT-A would be periodic re-calibration at the ICF. Changes in the performance of optical or signal processing chains can then be detected and corrected for in both instruments. Figure 1 shows a schematic of the channels 5 through 8.

* Correspondence: Email: george@atmosph.physics.utoronto.ca, Telephone: 416-971-2345, Fax: 416-978-8905

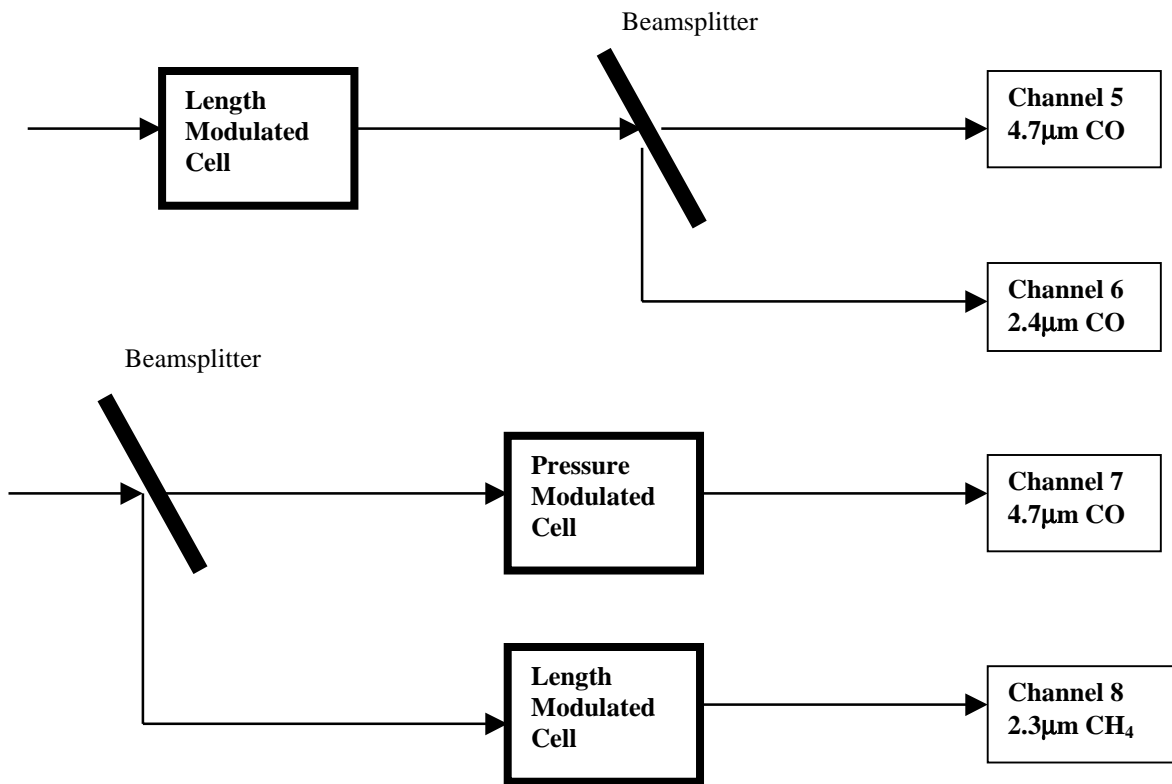

Figure 1: Schematic of Channels 5 through 8

2. INSTRUMENT DESIGN

2.1 Thermal

The design of MOPITT-A poses numerous design challenges. The change from a space-operating environment to an aircraft one impacted upon all areas of the instrument. Since the instrument is a near-IR spectrometer, thermal stability of the optical components is a critical concern. For this reason, it was decided that the pressurised forward sections of the ER-2 superpod would be best suited to maintain thermal stability. Although the pressure within this area is only 28kPa, some convective thermal exchange could be used advantageously. In addition, up to 2800W of heater power is available should additional heat be required.

In order to better understand the thermal conditions of the instrument in flight, a detailed thermal model was developed with the assistance of the original instrument contractors. Fortunately, the thermal models that had been developed for the FM instrument could be readily adapted for analysis of the aircraft instrument. Once the analysis was complete, the instrument was redesigned to include appropriate thermal control devices. Temperature sensors will be attached to key devices such as the optical assemblies, modulators and choppers. This information will be sent to the Instrument Control Computer (ICC), processed and then used to control area heaters as required.

MOPITT uses a British Aerospace Stirling Cycle cooler to cool its Indium Antimonide detector packages. These coolers are not well suited for use aboard the ER-2. Cooldown times obtained from the FM instrument indicated that about 16 hours were required to reach a stable temperature. This is well in excess of the eight hours that a typical ER-2 flight lasts. Other coolers were investigated, but none had the performance required. Liquid nitrogen cooled detectors have a long heritage aboard the aircraft. A series of tests were conducted at the UofT using a 51 LN₂ dewar with a simulated thermal interface and

loads. The results of these tests are shown in Figure 2. Cooldown times on the order of 30 minutes, comparable to the ascent time of the aircraft and hold times in excess of the eight-hour flight were achievable. Based on these results a 5l dewar incorporating pressure relief for boil-off was designed.

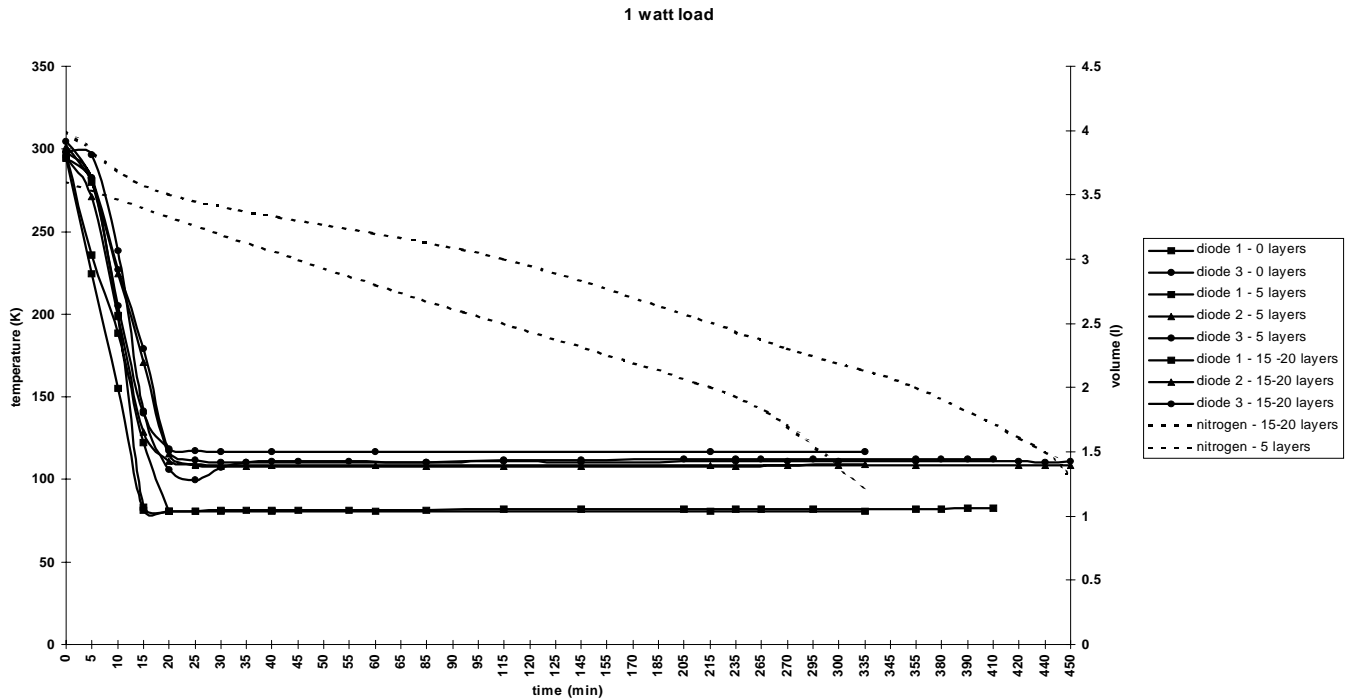

Figure 2. Graph of Cooldown Times

2.2 Mechanical

Since the thermal constraints drove the selection of the superpod as the location of the instrument, a number of mechanical constraints became imposed upon the design. The weight of the instrument could not exceed 68kg and the centre of gravity had to be as far aft as possible. The maximum dimensions are 69cm wide x 76cm high x 147cm long. Figure 3 shows a schematic of the instrument in the superpod.

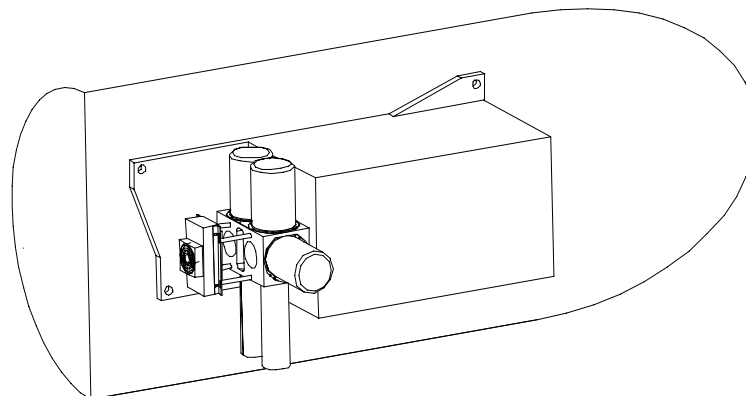

Figure 3. Schematic of Instrument in Superpod

With only 4 channels extant, it was possible to reduce the size of the EQM from that of the full MOPITT by removing the portion needed to mount channels 1 through 4. It was decided to mount the instrument with the baseplate normal to the earth's surface, instead of parallel as in MOPITT's case. This was due to the fact that the pressure modulated cell (PMC) would then have its piston's axis positioned in such a way that a 1g field would not affect it.

An important change to the instrument was the incorporation of a number of blackbodies to be used for in-flight calibration. Again, due to the short duration of the flights it was not possible to use MOPITT type blackbodies, as they required long periods to reach thermal stability. In order to allow for calibration at several different radiances, a calibration structure was designed that would have several sources set at 500K, 300K and 250K. By fixing the temperatures, it became possible to reach thermal stability within the 30-minute ascent time. The structure (Figure 4) is open to the ambient air in the nadir direction. Energy from the earth, or the blackbodies, is reflected off a 458 mirror, passed through a CaF₂ window and into the optical chain of the instrument. The entire calibration system is surrounded by a pressure enclosure in order to maintain the pressurisation of the pod.

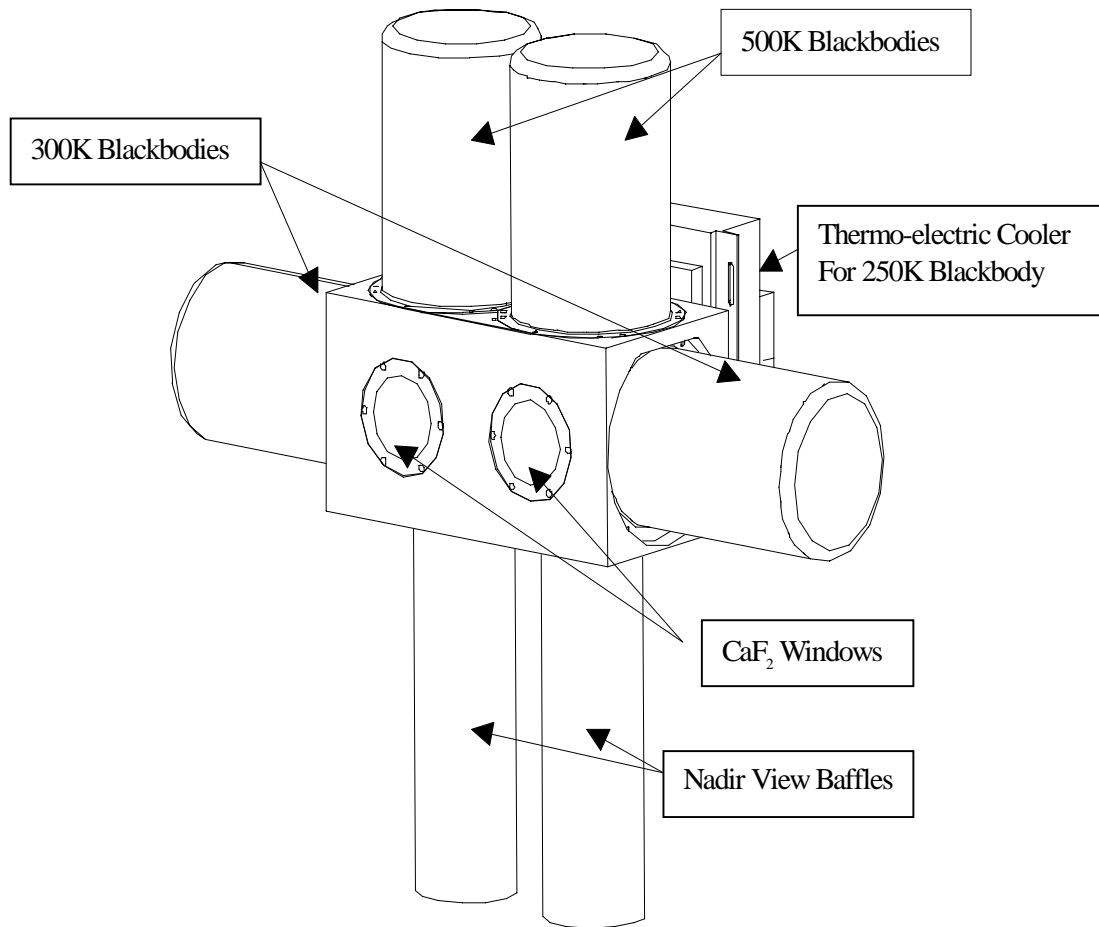

Figure 4. Drawing of calibration structure

Due to the mass restrictions of the ER-2 it was necessary to separate the electronics of the instrument from the optical system. The electronics will be housed in the midbody. In total the instrument will have a mass of 80kg distributed between the forward and midbody sections of the superpod.

2.3 Electronics

At the heart of the instrument is the Instrument Control Computer (ICC), a commercial single board Pentium computer with dual pressurised 6 Gigabyte hard disks. The ICC controls all functions of MOPITT-A. The modulators and choppers need to be synchronised with each other. A National Instruments PC-TIO-10 card is used to generate timing signals for these devices. These signals are then supplied to commercial motor drivers which have been selected to replace the costly custom drive circuits designed for the MOPITT instrument. Thermal sensors placed on critical instrument components are read through the serial port. This data is then analysed and used to control area heaters on the optical system. Output from the detectors is interfaced to the Signal Processing Module (SPM) which is identical to the MOPITT SPM. The resulting packetized data is then stored on the hard disks for post flight analysis. The ER-2 supplies time stamp and GPS data. A video camera will capture ground and cloud images then store this data to hard disk. Combining this data will give the science team information needed to accurately determine important ground feature locations such as coastlines, urban areas and forest fires.

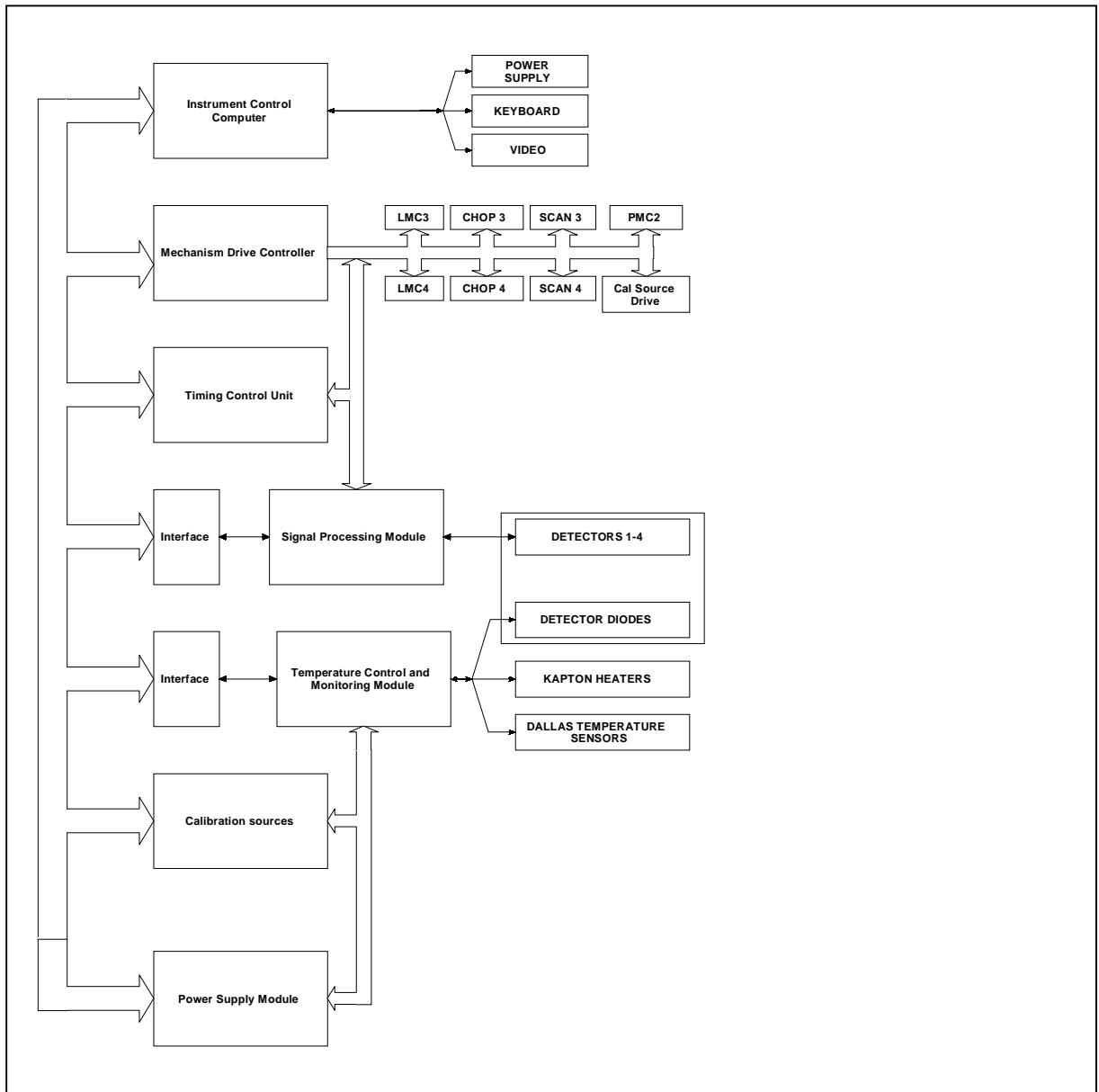

Figure 5. System Block Diagram

2.4 Optical

The optical system of MOPITT-A is comprised entirely of EQM optics. The detectors and their focusing optics are also designed to meet the characteristics of the satellite instrument. As mentioned earlier, these optics were designed to be as representative as possible of the MOPITT optics. During EQM testing a great deal of calibration data was generated, resulting in these components being well characterised. The channels which are being used will return data on CO concentrations at several altitudes, and methane column amounts, if the cells are filled to MOPITT pressure specifications. The cells will have the capability to be filled at other pressures pre-flight, thus shifting the weighting function cells. This in turn allows MOPITT-A to retrieve data from a wider range of altitudes.

3. CALIBRATION

In order to allow for inter-comparison of the aircraft and satellite instrument data, careful calibration of the MOPITT-A instrument is essential. The radiometric calibration of the EQM was performed at the UofT ICF in 1996. This procedure involved using a high precision blackbody as a source and measuring the response of the instrument as a function of blackbody temperature. Gas cells were placed between the source and instrument in order to simulate different atmospheric concentrations. These tests were repeated for MOPITT² in 1997 and will be performed on MOPITT-A. Periodic re-calibration of the aircraft instrument will allow the science team to identify long term changes in the instrument performance.

Field of view testing was also performed on both the EQM and FM MOPITT instruments. A collimated source is focused through the optical chain onto the detectors. The resulting spot on the detector is about 30µm and can be moved on the pixel surface in 50µm steps. This allowed accurate mapping of the pixel response as a function of position. Again, these tests will be repeated in order to detect changes in detector response.

Within the detector and cold optics assemblies are narrowband filters at 2.3 or 4.7µm depending on the channel. As part of the earlier calibration testing a technique was developed using the Difference Frequency Laser (DFL) system that exists at UofT. The technique involves precisely varying the wavelength of narrow band IR energy and mapping the response of the instrument. The resulting instrument response corresponds to the bandpass response of the filters. As part of MOPITT-A calibration these tests will be repeated and compared to EQM data taken in 1996. Any shifts due to ageing of the filter coatings will be readily apparent.

A final set of tests will be performed in which the instrument temperature will be varied and changes in response measured. Test data gathered will be compared to previous EQM and MOPITT results performed at UofT and Lockheed Martin's Valley Forge facility. These comparisons will indicate long term instrument performance changes as well as allow for correction of MOPITT-A flight data should the instrument experience changes to its thermal environment

4. SUMMARY

The MOPITT-A instrument will be a key component in the data validation effort for MOPITT. Due to its relative ease of calibration, and long calibration history, it will provide a standard against which MOPITT data can be compared. The use of flight quality optics and signal processing electronics will help to ensure that MOPITT-A data will provide accurate data validation. Because it can be deployed aboard the ER-2 it will be possible to gather data not only for validation, but also as an integral part of other campaigns.

ACKNOWLEDGEMENTS

The authors wish to acknowledge the efforts of the following MOPITT-A engineering team members, Ron Irvine, Paul Ruppert, Dan Pich, Gurmit Besla and Sophie Kerambrun. They would also like to acknowledge the participation of BOMEM in designing and supplying the calibration sources and COM DEV International for performing the instrument thermal design. The funding for the MOPITT-A project is supplied by the Canadian Space Agency.

REFERENCES

1. J. Wang, J.C. Gille, P.L. Bailey, M.W. Smith, D. Edwards, J.R. Drummond, G.R. Davis, H.Reichle, "Measurement of Pollution in the Troposphere (MOPITT) Data Validation Plan", MOPITT Internal Document
2. G.S. Mand, G.V. Bailak, Z.Z. Yu, B.T. Tolton, E. McKernan, J.R. Drummond, "Preflight Testing of the MOPITT instrument", 44th SPIE Meeting and Exhibition, Denver, 1999.